

2

1

B

B

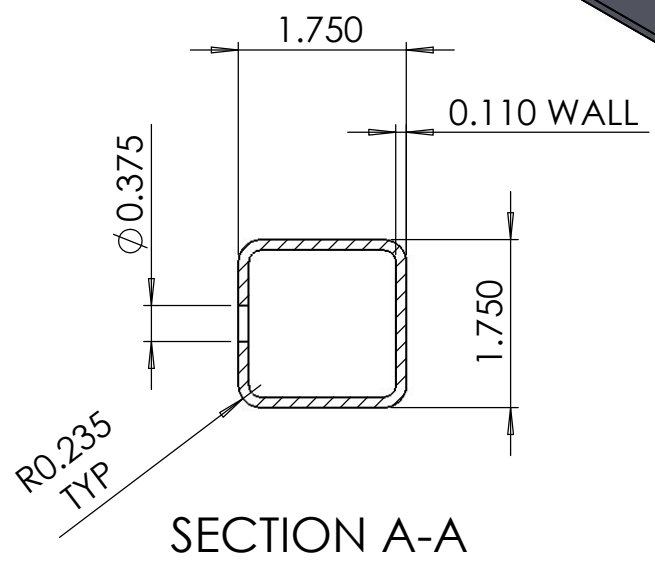
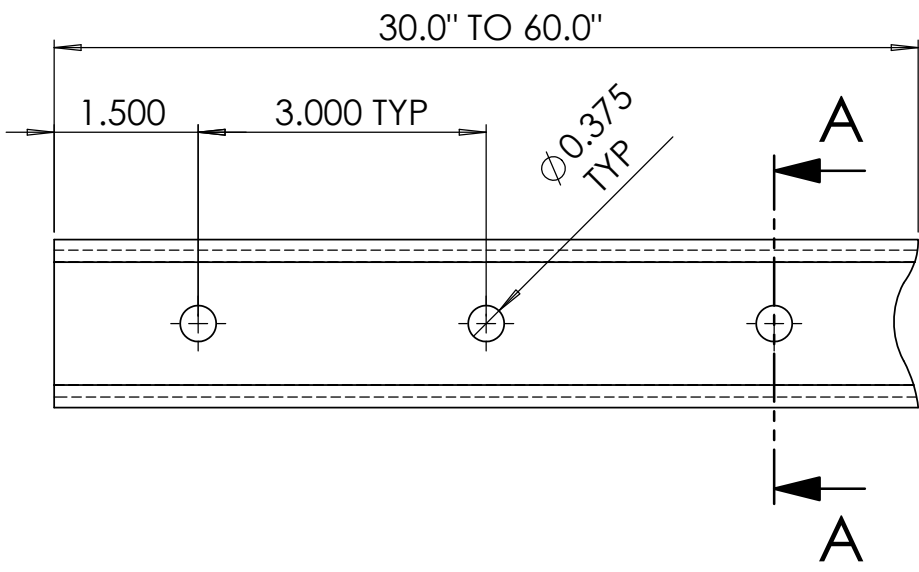
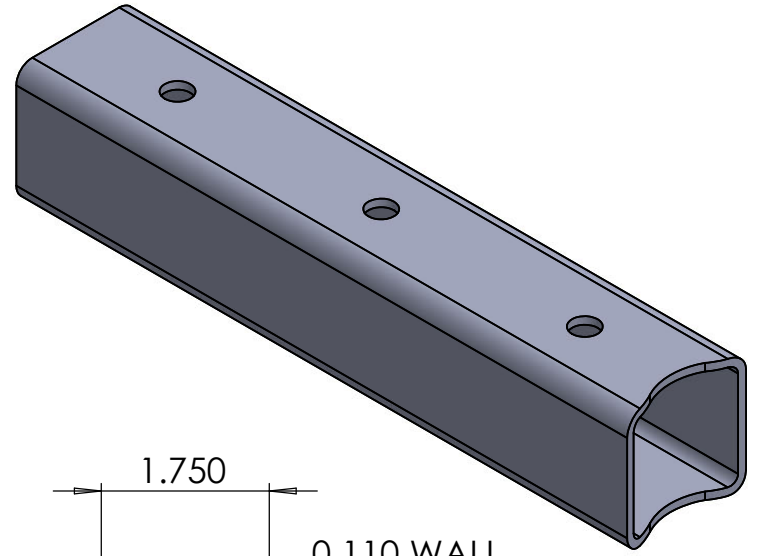

A

A

**PROPRIETARY AND CONFIDENTIAL**  
 THE INFORMATION CONTAINED IN THIS DRAWING IS THE SOLE PROPERTY OF <INSERT COMPANY NAME HERE>. ANY REPRODUCTION IN PART OR AS A WHOLE WITHOUT THE WRITTEN PERMISSION OF <INSERT COMPANY NAME HERE> IS PROHIBITED.

		UNLESS OTHERWISE SPECIFIED:		NAME	DATE
		DIMENSIONS ARE IN INCHES	DRAWN	STEVE I	5-13-19
		TOLERANCES:	CHECKED		
		FRACTIONAL $\pm$	ENG APPR.		
		ANGULAR: MACH $\pm$ BEND $\pm$	MFG APPR.		
		TWO PLACE DECIMAL $\pm$	Q.A.		
		THREE PLACE DECIMAL $\pm$	COMMENTS:		
		INTERPRET GEOMETRIC TOLERANCING PER:			
		MATERIAL			
		ALUMINUM			
		FINISH			
NEXT ASSY	USED ON				
APPLICATION		DO NOT SCALE DRAWING			

 <b>ALCOBRA</b>		
<b>TELESCOPING TUBING</b>		
SIZE	DWG. NO.	REV
<b>A</b>	<b>AQT1.75FPM</b>	
SCALE: 1:2	WEIGHT:	SHEET 1 OF 1

2

1